

# GS-EVB-IMS3-xxxxxxxB-GS

GS-EVB-IMS3-66508B-GS  
GS-EVB-IMS3-66516B-GS  
GS-EVB-IMS3-0650603B-GS  
High Power IMS 3 Evaluation Platform

## Technical Manual

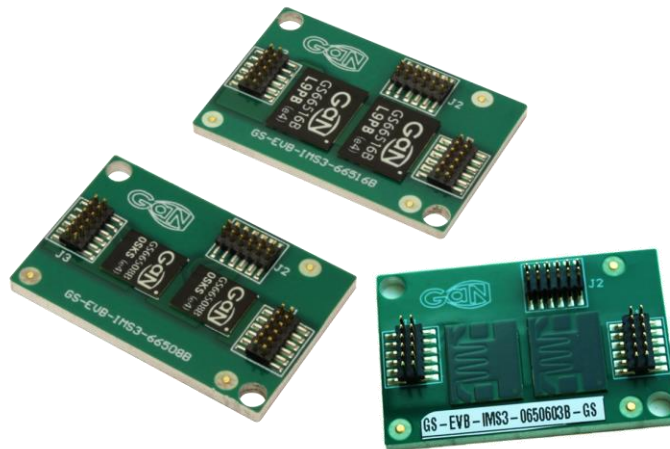

Visit [www.gansystems.com](http://www.gansystems.com) for the latest version of this technical manual.

## DANGER



DO NOT TOUCH THE BOARD WHEN IT IS ENERGIZED AND ALLOW ALL COMPONENTS TO DISCHARGE COMPLETELY PRIOR HANDLING THE BOARD.

HIGH VOLTAGE CAN BE EXPOSED ON THE BOARD WHEN IT IS CONNECTED TO POWER SOURCE. EVEN BRIEF CONTACT DURING OPERATION MAY RESULT IN SEVERE INJURY OR DEATH.

Please sure that appropriate safety procedures are followed. This evaluation kit is designed for **engineering evaluation in a controlled lab environment and should be handled by qualified personnel ONLY**. Never leave the board operating unattended.



### WARNING

Some components can be hot during and after operation. **There is NO built-in electrical or thermal protection on this evaluation kit**. The operating voltage, current, and component temperature should be monitored closely during operation to prevent device damage.



### CAUTION

This product contains parts that are susceptible to damage by electrostatic discharge (ESD). Always follow ESD prevention procedures when handling the product.

---

## Contents

1	Overview.....	5
1.1	Introduction .....	5
1.2	Features and Benefits .....	5
1.3	Applications .....	5
1.4	Contents.....	5
2	Technical Specifications of IMS 3 Half Bridge Daughter Power Board .....	7
2.1	On-board GaN E-mode Transistors .....	7
2.2	IMS3 Board Thermal Design.....	7
2.3	IMS3 Half Bridge Board Design .....	10
3	Compatible Driver Motherboard Options.....	11
4	Operation Modes .....	13
5	Test Results .....	15
5.1	Double Pulse Test (GS-EVB-HBDB-IMS + GS-EVB-IMS3-66508B-GS) .....	15
5.2	Boost Configuration Test (GS-EVB-HBDB-IMS + GS-EVB-IMS3-66508B-GS) .....	17
6	GS-EVB-IMS3-665xxB-GS Schematics and BoM.....	19

## List of Figures

Figure 1	IMS3 daughter power boards with heatsinks .....	5
Figure 2	GS-065-060-3-B, GS66516B and GS66508B GaNPX® packaged GaN E-mode transistors .....	7
Figure 3	Cross-section view of a single layer IMS3 board .....	8
Figure 4	Comparison of junction to heatsink thermal resistance ( $R_{thj-HS}$ ) (Estimated based on GS66516B) ..	9
Figure 5	IMS3 half-bridge daughter power board (GS-EVB-IMS3-66508B-GS).....	10
Figure 6	Compatible driver motherboards .....	11
Figure 7	Double pulse test setup schematics .....	15
Figure 8	Double pulse test setup .....	15
Figure 9	Double pulse test waveforms (400V/30A).....	16
Figure 10	Boost configuration test setup schematics .....	17
Figure 11	Boost configuration test setup .....	17
Figure 12	Boost configuration test thermal measurement result .....	18
Figure 13	Test waveforms (400Vin, 10kHz, Po=0.8kW).....	18

## List of Tables

Table 1	GS-EVB-IMS3-xxxxxxxB-GS Evaluation Kit Contents .....	5
Table 2	IMS3 daughter power board part numbers and description .....	6
Table 3	Performance comparison of 2 thermal design options for SMT power devices.....	8
Table 4	Compatible driver motherboards for IMS3 daughter power board GS-EVB-IMS3-xxxxxxxB-GS ..	11
Table 5	Driver motherboard part numbers and description .....	12
Table 6	Half bridge configurations operation mode using GS-EVB-HBDB-IMS .....	13
Table 7	dual half bridge/full bridge configurations operation mode using GSP665HPMB-EVBIMS2.....	14

# 1 Overview

## 1.1 Introduction

This horizontal Insulated Metal Substrate (IMS3) evaluation platform can be used to evaluate the electrical and thermal performance benefits of GaNPX® bottom-side cooled E-modes in high power applications. The optimized thermal and electrical designs provide an excellent reference for implementing a low cost, high performance design.

## 1.2 Features and Benefits

- Improved heat transfer
- Increased power density
- Reduced system cost
- High thermal conductivity (7.0 W/mK)

## 1.3 Applications

- Automotive: 3.3kW-22kW on board charger, DC/DC, 3-Φ inverter, high power wireless charger
- Industrial: 3-7kW Photovoltaic Inverter and Energy Storage System (ESS), Motor Drive / VFD
- Server/Datacenter: 3kW Server ACDC power supply.
- Consumer: Residential Energy Storage System (ESS)

## 1.4 Contents

As referred to Figure 1, the GS-EVB-IMS3-xxxxxxB-GS includes the following hardware in Table 1:

Table 1 GS-EVB-IMS3-xxxxxxB-GS Evaluation Kit Contents

Quantity	Description
1	GS-EVB-IMS3-66508B-GS 3 kW Half Bridge Daughter Power Board
1	GS-EVB-IMS3-66516B-GS 6 kW Half Bridge Daughter Power Board
1	GS-EVB-IMS3-0650603B-GS 6 kW Half Bridge Daughter Power Board

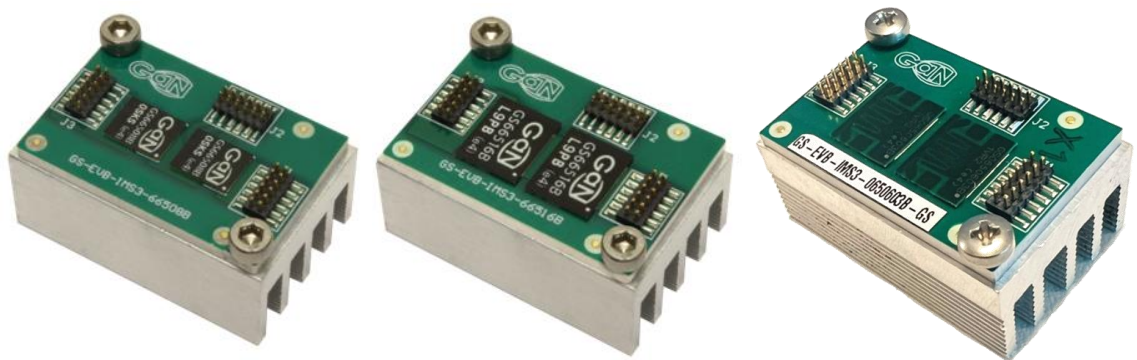

a)GS-EVB-IMS3-66508B-GS

b) GS-EVB-IMS3-66516B-GS

c) GS-EVB-IMS3-0650603B-GS

Figure 1 IMS3 daughter power boards with heatsinks



A suitable heatsink is included for lower power applications. For higher power applications additional heatsinking may be required. To prevent device damage, ensure adequate heatsinking through design and by monitoring the component temperatures during operation.



To assemble a heatsink, apply thermal grease to the heatsink / IMS board interface before screwing the units together. Enough thermal grease should be applied so that a small amount extrudes on all four sides as the screws are tightened. Wipe the assembly clean.

The ordering information is listed in Table 2 below:

Table 2 IMS3 daughter power board part numbers and description

PART NUMBER	DESCRIPTION	POWER LEVEL	GaN E-mode
GS-EVB-IMS3-66508B-GS	650 V GaN High Power IMS3 Half Bridge	3 kW	GS66508B
GS-EVB-IMS3-66516B-GS	650 V GaN High Power IMS3 Half Bridge	6 kW	GS66516B
GS-EVB-IMS3-0650603B-GS	650 V GaN High Power IMS3 Half Bridge	6 kW	GS-065-060-3-B

## 2 Technical Specifications of IMS 3 Half Bridge Daughter Power Board

### 2.1 On-board GaN E-mode Transistors

Using this platform, power designers can evaluate the performance of GaN Systems’ E-mode transistors in high power, high-efficiency applications. The IMS3 half-bridge daughter power board is populated with GaN Systems’ GS-065-060-3-B (bottom-side cooled GaN E-mode transistor, rated at 650 V / 25 mΩ) or GS66516B (bottom-side cooled GaN E-mode transistor, rated at 650 V / 25 mΩ) or GS66508B (bottom-side cooled GaN E-mode transistor, rated at 650 V / 50 mΩ), as shown in Figure 2. The embedded GaNPX® SMD package has the following features:

- Large power source/thermal pad for improved thermal dissipation.
- Bottom-side cooled packaging for conventional PCB or advanced IMS/Cu inlay thermal design.
- Ultra-low inductance for high-frequency switching.

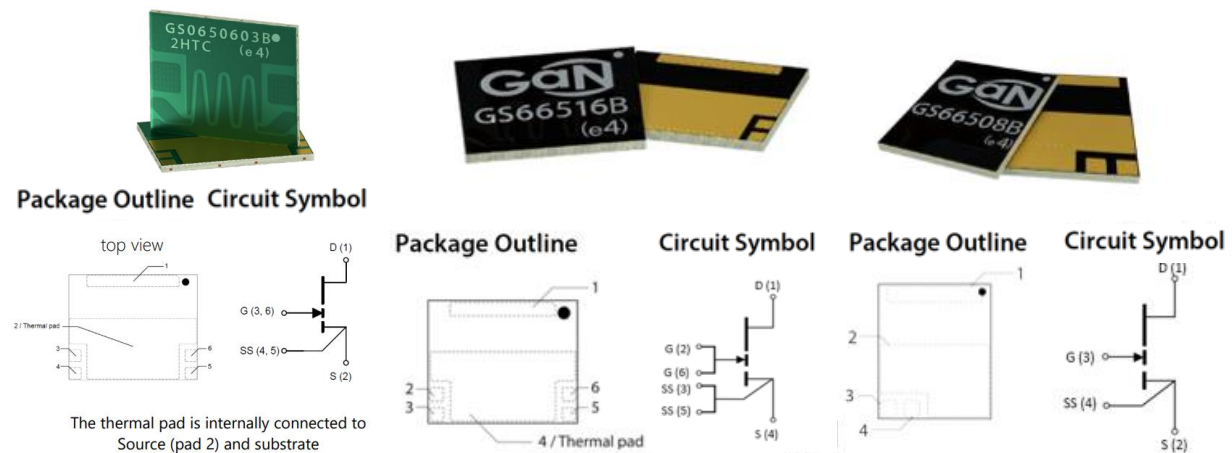

Figure 2 GS-065-060-3-B, GS66516B and GS66508B GaNPX® packaged GaN E-mode transistors

The IMS3 half-bridge daughter power board is designed for users to gain hands-on experience in the following ways:

- Evaluate the GaN E-mode transistors performance in any half-bridge-based topology, over a range of operating conditions.
- Use as a thermal and electrical design reference of the GS-065-060-3-B / GS66516B / GS66508B GaNPX® package in demanding high-power and high-efficiency applications.

### 2.2 IMS3 Board Thermal Design

An IMS3 power daughter board assembly uses metal as the PCB core, to which a dielectric layer and copper foil layers are bonded, as shown in Figure 3. The metal PCB core is often aluminum. The copper foil layers can be single or double-sided. An IMS3 board offers superior thermal conductivity to standard FR4 PCB. It’s commonly used in high-power, high current applications where most of the heat is concentrated in a small footprint SMT device.

As high-speed Gallium Nitride power devices are adopted widely, the industry is trending away from through-hole packaging (TH), towards surface-mount packaging (SMT). Traditional TH devices, such as the TO-220, are no longer the appropriate choice because their high parasitic inductance and capacitance negate the performance benefits offered by GaN E-mode transistors. SMT packaging, such as PQFN,

D2PAK, and GaN Systems' GaN<sup>®</sup>PX<sup>®</sup>, by comparison, offer low inductance and low thermal impedance, enabling efficient designs at high power and high switching frequency.

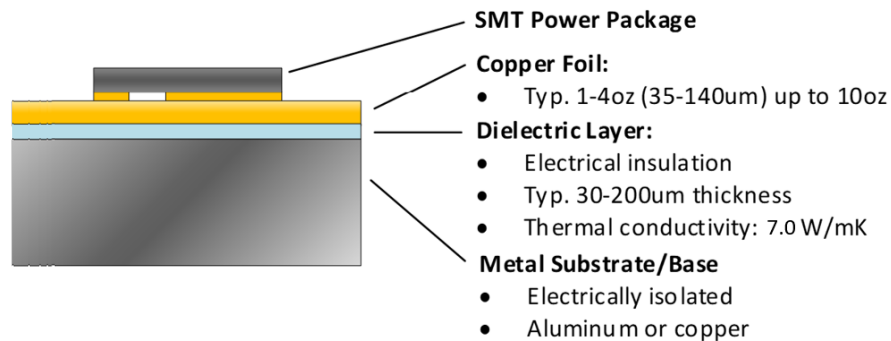

Figure 3 Cross-section view of a single layer IMS3 board

Thermal management of SMT power transistors must be approached differently than TH devices. TO packages are cooled by attaching them to a heatsink, with an intermediary Thermal Interface Material (TIM) sheet for electrical high voltage insulation. The traditional cooling method for SMT power devices is to use thermal vias tied to multiple copper layers in a PCB. The IMS3 board presents designers with another option which is especially useful for high power applications. The IMS 3 board has a much lower junction to heatsink thermal resistance ( $R_{thj-HS}$ ) than FR4 PCBs, for efficient heat transfer out of the transistor. As well, assembly on an IMS3 board has lower assembly cost and risk than the TH alternative. The manual assembly process of a TO package onto a heatsink is costly and prone to human error.

Table 3 compares 2 different design approaches for cooling discrete SMT power devices. While the cost is lower for an FR4 PCB cooling with thermal vias, the IMS 3 board offers the best performance for thermal management. Figure 4 provides a quantitative comparison of the thermal resistance for the 2 design options. The IMS3 board clearly comes out ahead.

Table 3 Performance comparison of 2 thermal design options for SMT power devices

	FR4 PCB Cooling with Vias	IMS PCB
<b>Thermal resistance</b>	<b>Good</b>	<b>Best</b>
<b>Electrical Insulation</b>	Use TIM	<b>Yes</b>
<b>Cost</b>	Lowest	<b>Low</b>
<b>Advantages</b>	<ul style="list-style-type: none"> <li>• Standard process</li> <li>• Layout flexibility</li> </ul>	<ul style="list-style-type: none"> <li>• <b>Electrically isolated</b></li> </ul>
<b>Design challenges</b>	<ul style="list-style-type: none"> <li>• High PCB thermal resistance</li> </ul>	<ul style="list-style-type: none"> <li>• Usually layout limited to 1 layer</li> <li>• Parasitic inductance</li> <li>• Coupling capacitances to the metal substrate</li> </ul>



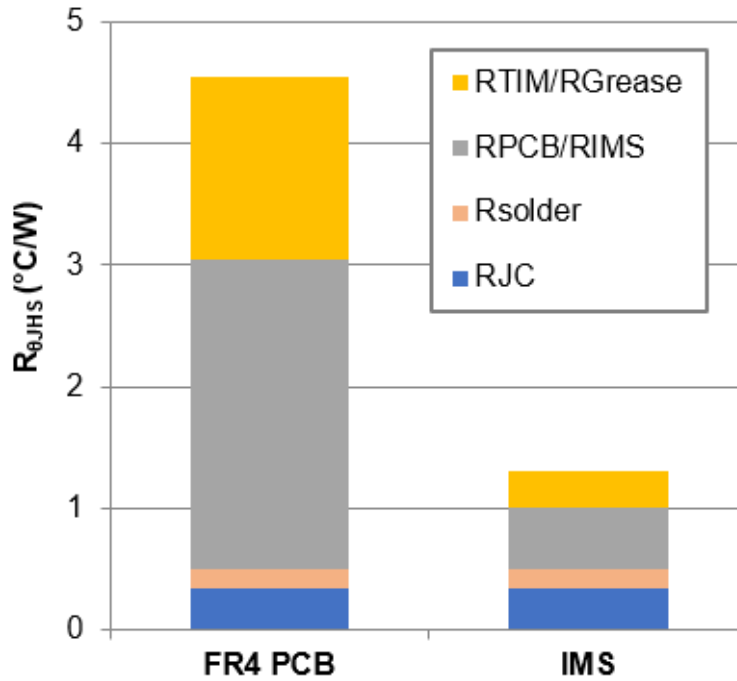

Figure 4 Comparison of junction to heatsink thermal resistance (R<sub>thJ-HS</sub>) (Estimated based on GS66516B)

The following additional measures are taken to optimize the design further.

- The IMS3 evaluation platform is implemented as a two-board assembly. The gate drive circuitry is assembled on the GS-EVB-HBDB-IMS, a multi-layer FR4 PCB motherboard. This includes the gate driver ICs, an isolated push-pull power supply to power the driver IC, and DC decoupling capacitors. The GaN E-mode transistors are mounted to the IMS3 half-bridge daughter power boards (GS-EVB-IMS3-0650603B-GS, GS-EVB-IMS3-66508B-GS and GS-EVB-IMS3-66516B-GS). This approach addresses the shortcomings of implementing the design on a single layer IMS board.
- While a large copper area is preferred to maximize heat spreading and handle high current, the area of copper at the switching node (high dv/dt) needs to be minimized to reduce the parasitic coupling capacitance to the metal substrate. An IMS 3 board with a thicker dielectric layer (100um) is chosen on this design to further reduce this effect.

### 2.3 IMS3 Half Bridge Board Design

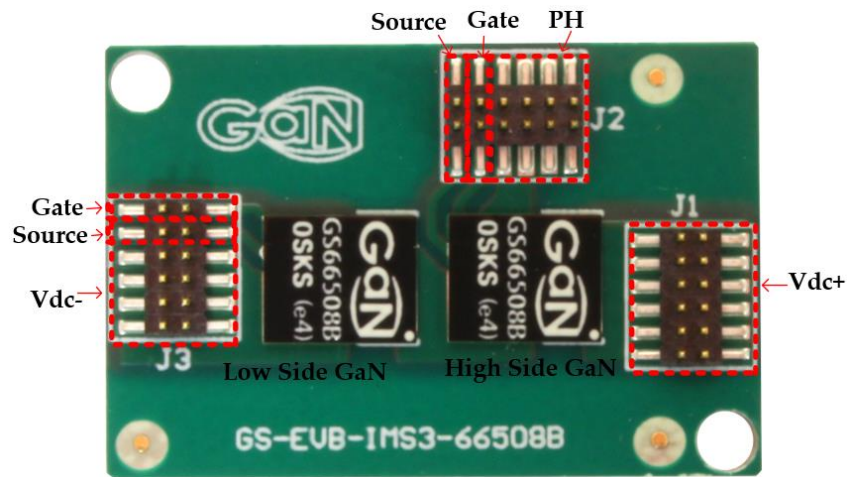

Figure 5 IMS3 half-bridge daughter power board (GS-EVB-IMS3-66508B-GS)

The IMS3 half-bridge daughter power board is populated with the following components:

- **Q1 and Q2:** GaN E-HEMTs in a half-bridge configuration.
  - 6kW GS-EVB-IMS3-0650603B-GS: Q1/Q2 GS-065-060-3-B.
  - 6kW GS-EVB-IMS3-66516B-GS: Q1/Q2 GS66516B.
  - 3kW GS-EVB-IMS3-66508B-GS: Q1/Q2 GS66508B.
- **J1, J2, J3:**
  - Connector Header Surface Mount 12 position 0.050" (1.27mm) (Samtec Inc., P/N: FTS-106-02-F-DV).
  - These terminals are designed to carry the main current and gate signals.

### 3 Compatible Driver Motherboard Options

The IMS3 half bridge daughter power board can be used in both half bridge and full bridge configuration. The IMS3 half bridge daughter power board are compatible with two different driver motherboards, as shown in Figure 6. The ordering options are listed in Table 4 below:

Table 4 Compatible driver motherboards for IMS3 daughter power board GS-EVB-IMS3-xxxxxxB-GS

CONFIGURATION	DRIVER MOTHERBOARD
Half Bridge	GS-EVB-HBDB-IMS
Dual Half Bridge / Full Bridge	GSP665HPMB-EVBIMS2

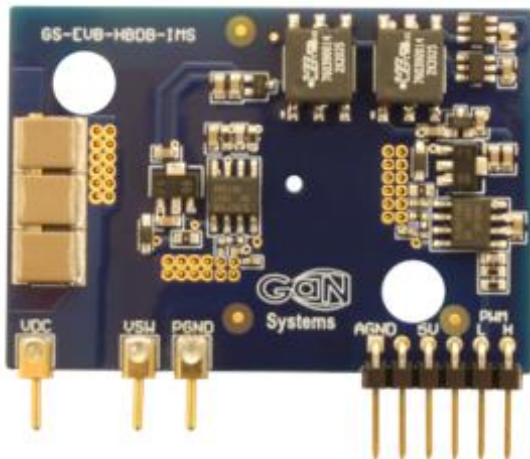

a) GS-EVB-HBDB-IMS



b) GSP665HPMB-EVBIMS2

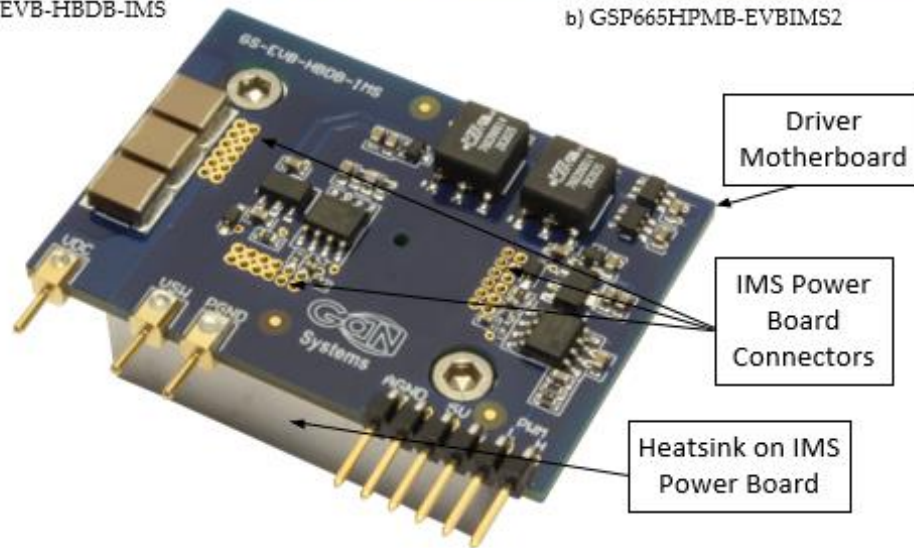

c) Assembled IMS3 EVB module using GS-EVB-HBDB-IMS

Figure 6 Compatible driver motherboards

The ordering information are listed in Table 5 below:

Table 5 Driver motherboard part numbers and description

PART NUMBER	DESCRIPTION
GS-EVB-HBDB-IMS	650 V Universal Half Bridge Isolated Driver Motherboard for IMS2 & IMS3
GSP665HPMB-EVBIMS2	650 V Universal High-Power Dual Half Bridge / Full Bridge Driver Motherboard for IMS2 & IMS3

For more information related to the driver mother boards about their:

- Features and Benefits
- Applications
- Technical Specifications (design overview, gate driver circuit, 5V input and external PWM signals input, temperature monitoring hole, installation of IMS half-bridge daughter power board, and DC link decoupling capacitors)
- Schematics and BoM

please refer to driver mother boards technical manuals on <https://gansystems.com/evaluation-boards/>

## 4 Operation Modes

The IMS3 EVB half-bridge daughter power boards can be configured into different topologies and operation modes with the two driver motherboards, as shown below:

Table 6 Half bridge configurations operation mode using GS-EVB-HBDB-IMS

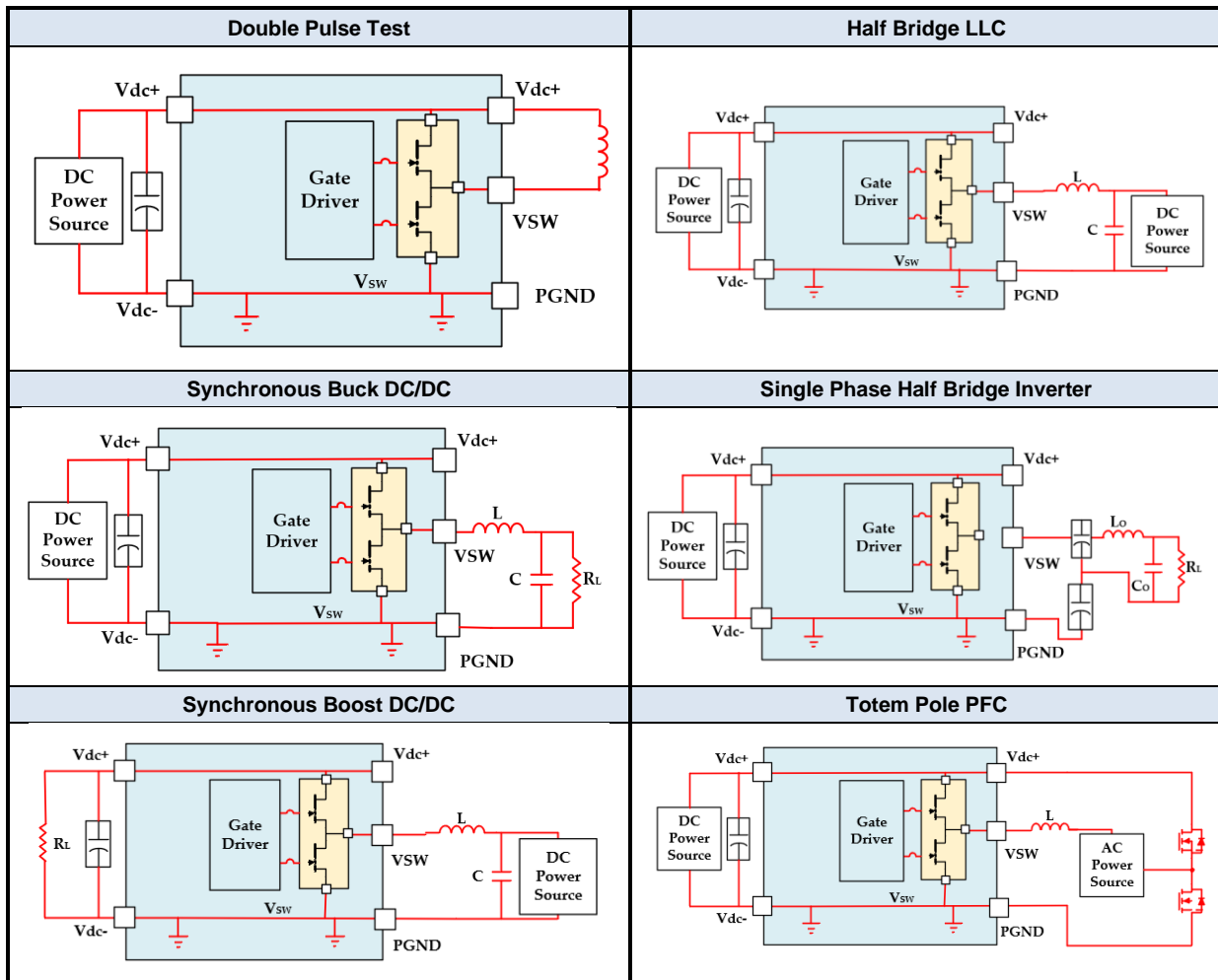
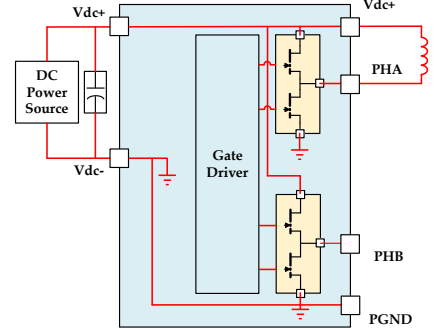
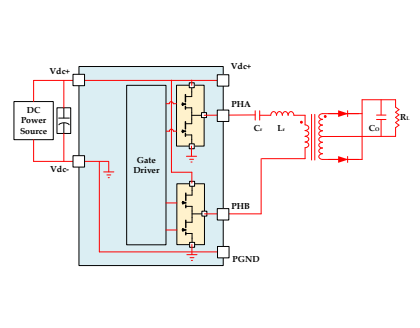
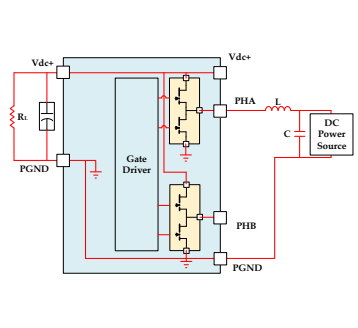
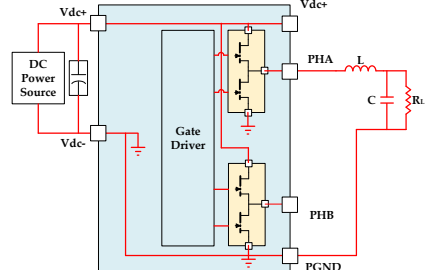
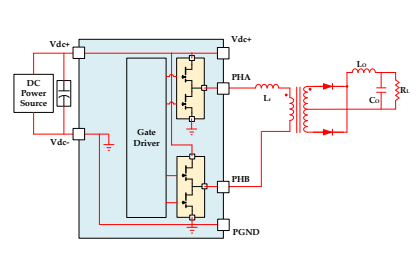
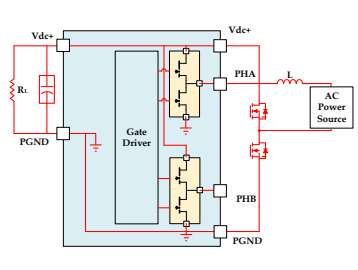
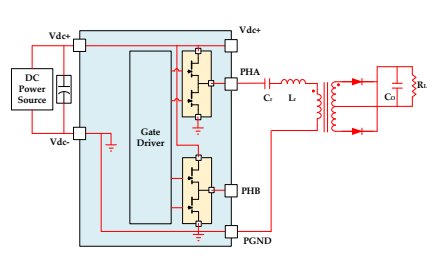
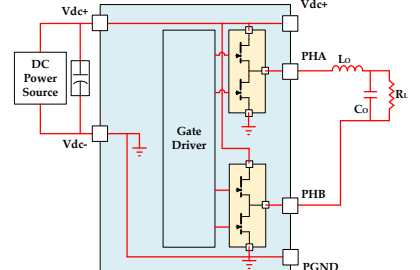
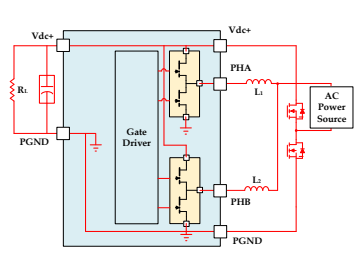
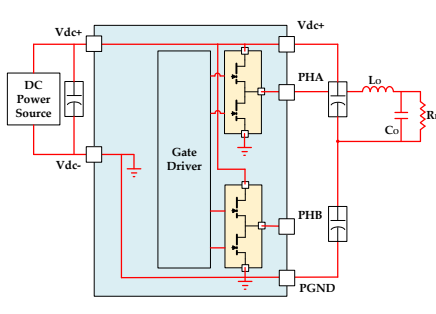
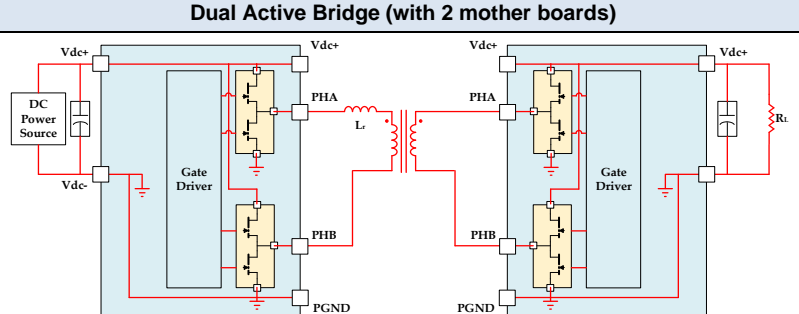

Table 7 dual half bridge/full bridge configurations operation mode using GSP665HPMB-EVBIMS2

HALF BRIDGE	FULL BRIDGE	BOOST MODE
<p><b>Double Pulse Test</b></p> 	<p><b>Full Bridge LLC</b></p> 	<p><b>Synchronous Boost DC/DC</b></p> 
<p><b>Synchronous Buck DC/DC</b></p> 	<p><b>Phase Shift Full Bridge</b></p> 	<p><b>Totem Pole PFC</b></p> 
<p><b>Half Bridge LLC</b></p> 	<p><b>Full Bridge Inverter</b></p> 	<p><b>Interleaved Totem Pole PFC</b></p> 
<p><b>Single Phase Half Bridge Inverter</b></p> 	<p><b>DUAL ACTIVE BRIDGE</b></p> <p><b>Dual Active Bridge (with 2 mother boards)</b></p> 	

## 5 Test Results

### 5.1 Double Pulse Test (GS-EVB-HBDB-IMS + GS-EVB-IMS3-66508B-GS)

- Test condition:  $V_{DS} = 400V$ ,  $I_D = 30A$ ,  $V_{GS} = +6V/-3V$ ,  $L = 37\mu H$ , No RC Snubber,  $T_J = 25^\circ C$
- Measured peak  $V_{DS} = 630V$  and  $92 V/ns$  peak  $dV/dt$
- Reliable hard switching with GS66508B is achieved at full rated current

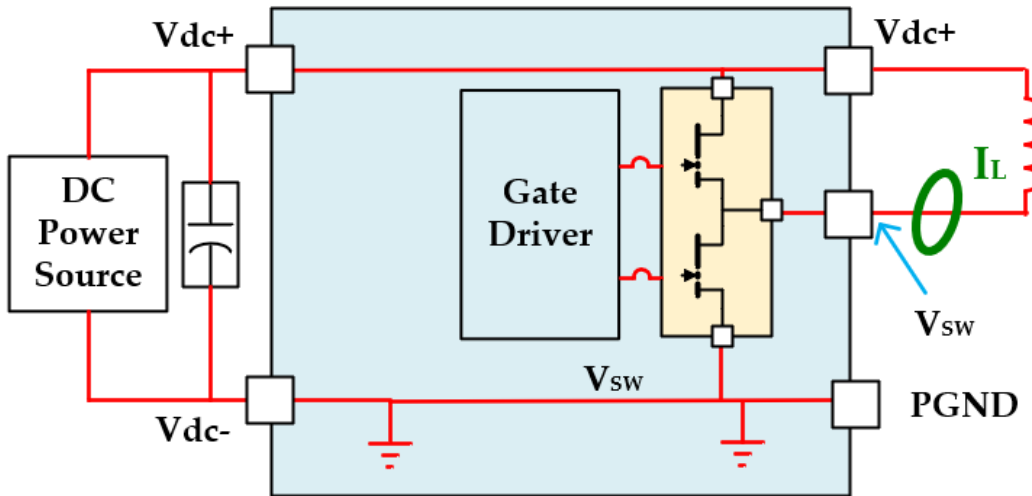

Figure 7 Double pulse test setup schematics

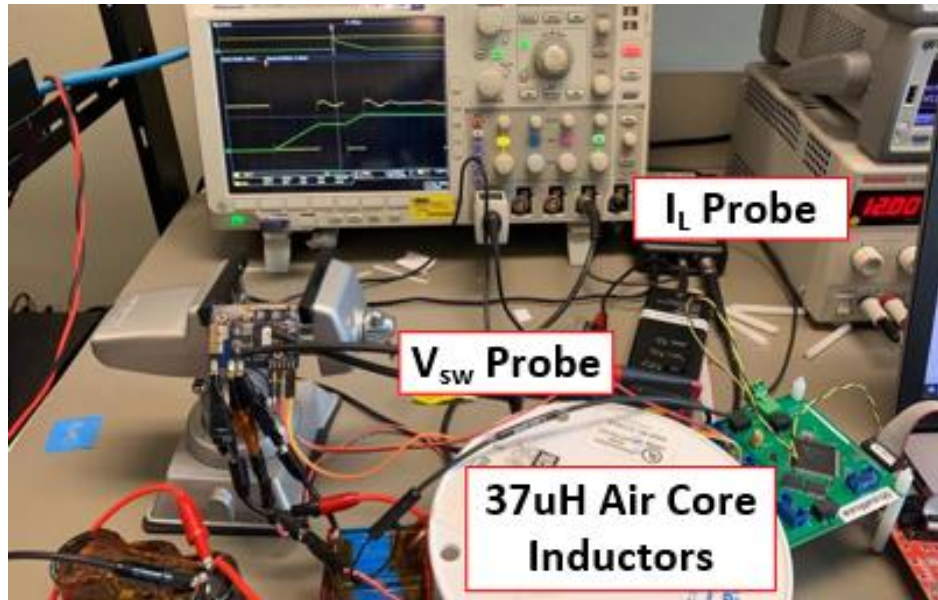

Figure 8 Double pulse test setup

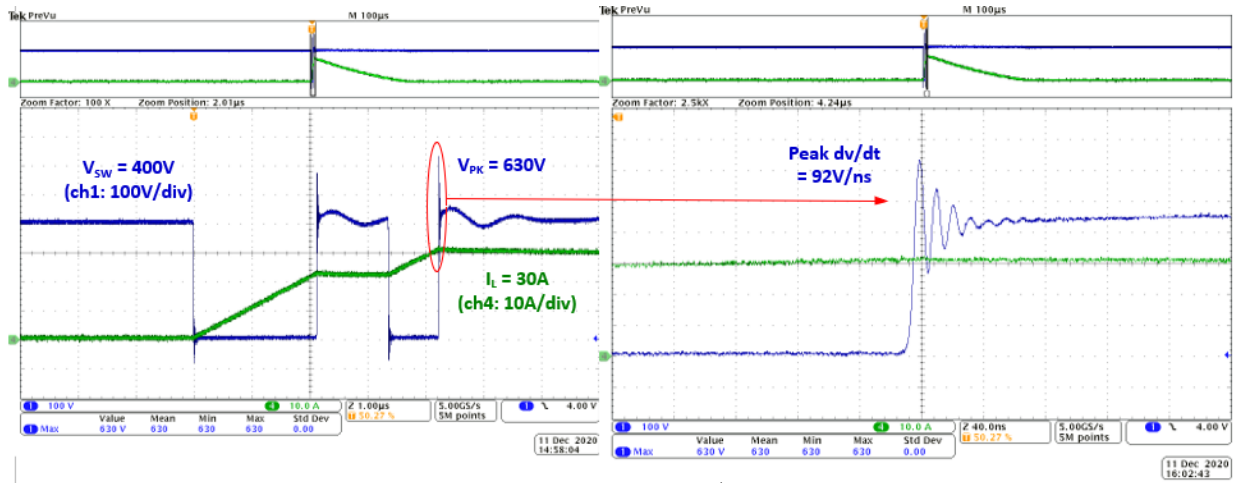

Figure 9 Double pulse test waveforms (400V/30A)



## 5.2 Boost Configuration Test (GS-EVB-HBDB-IMS + GS-EVB-IMS3-66508B-GS)

- Test condition:  $V_{IN} = 400V$ ,  $f_{sw}=10kHz$ ,  $P_O=0.8kW$ ,  $T_{AMB} = 25^{\circ}C$ .
- Device case temperature  $72^{\circ}C$

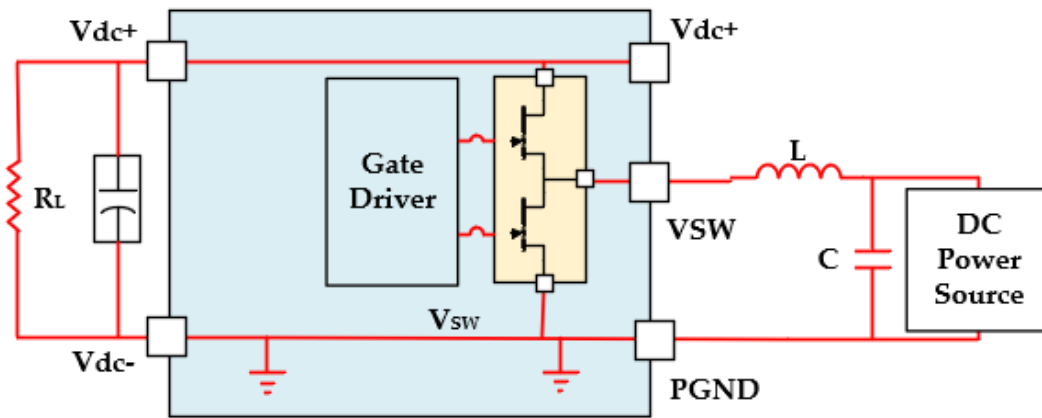

Figure 10 Boost configuration test setup schematics

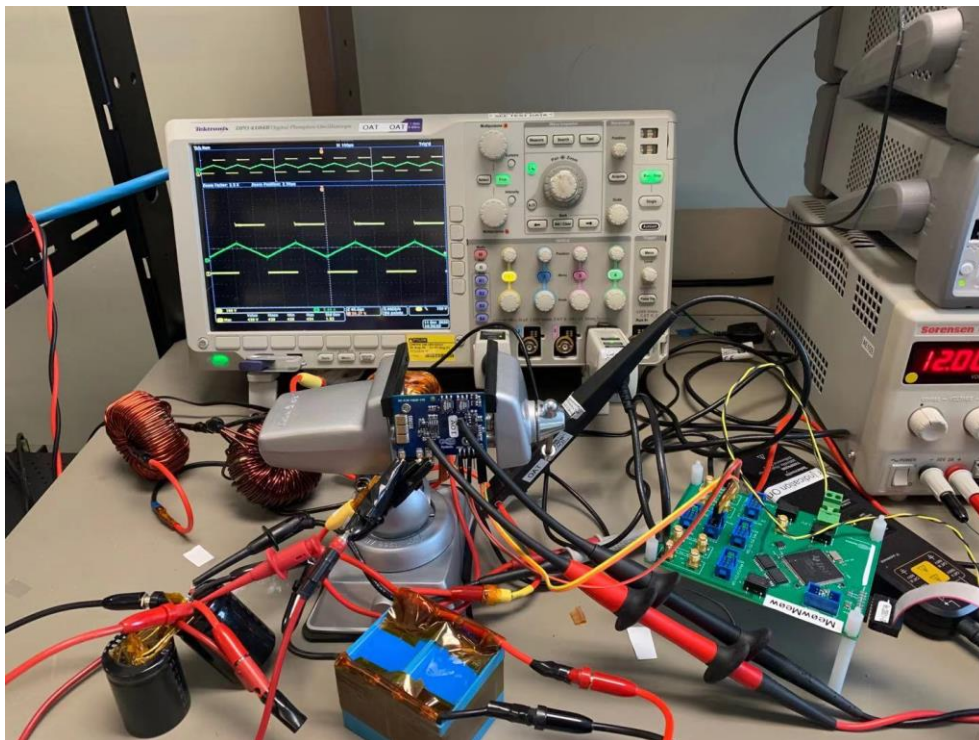

Figure 11 Boost configuration test setup



Figure 12 Boost configuration test thermal measurement result

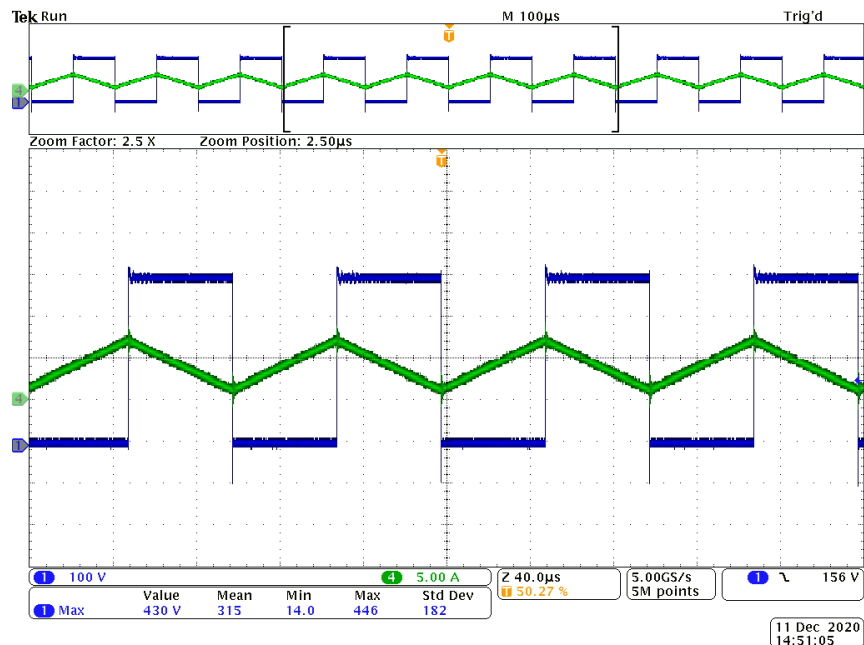
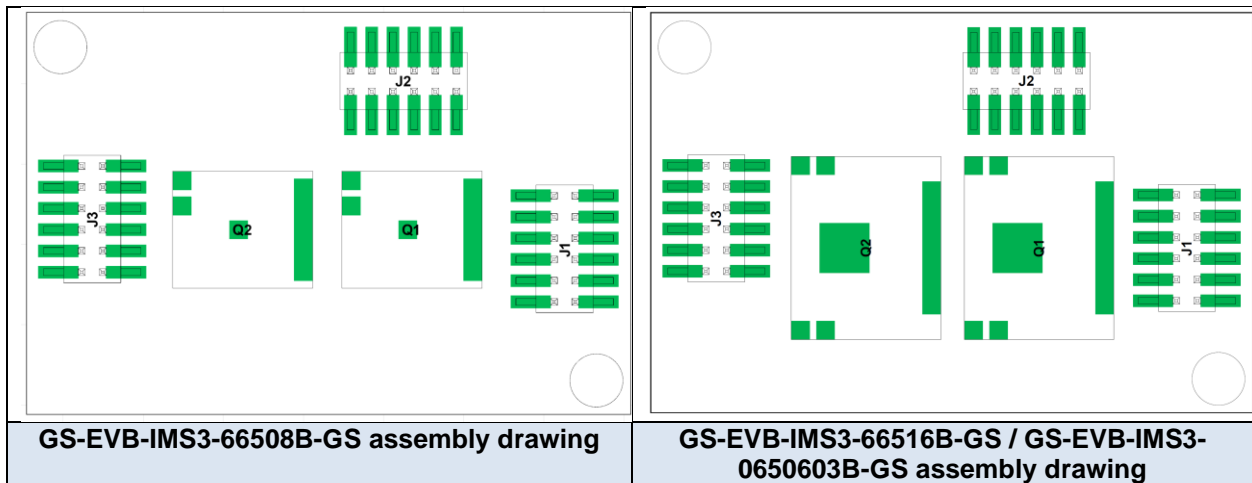
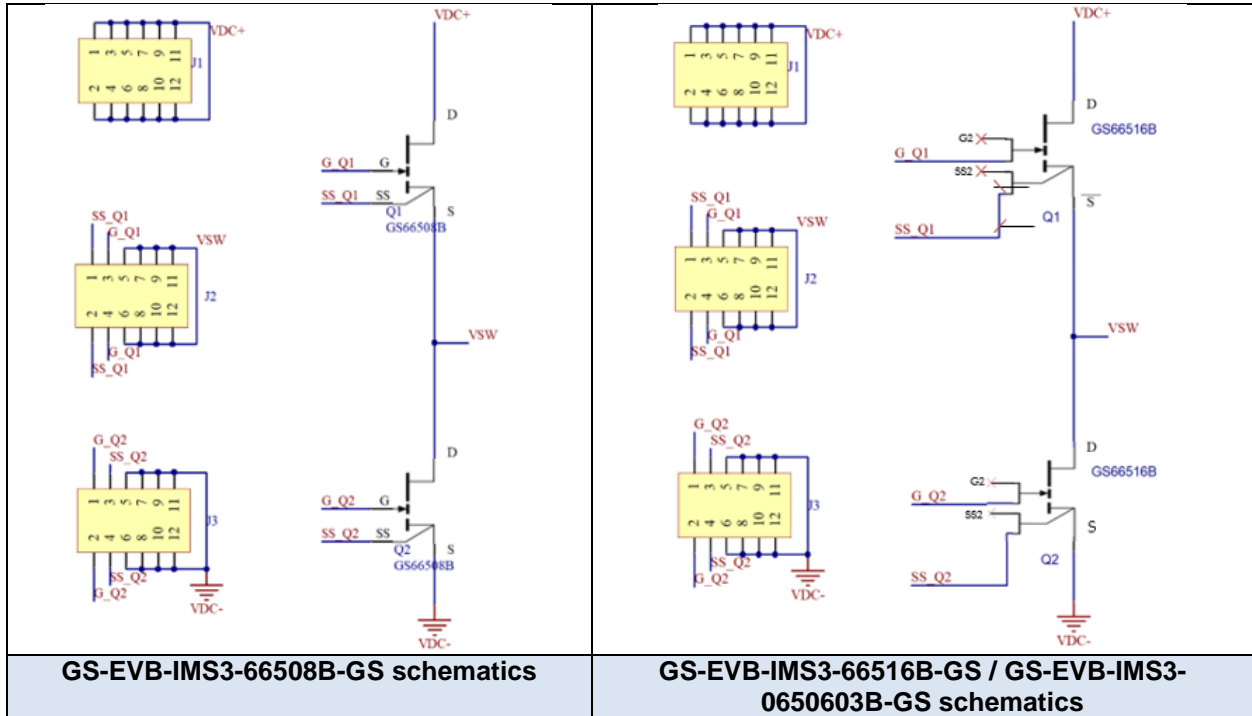
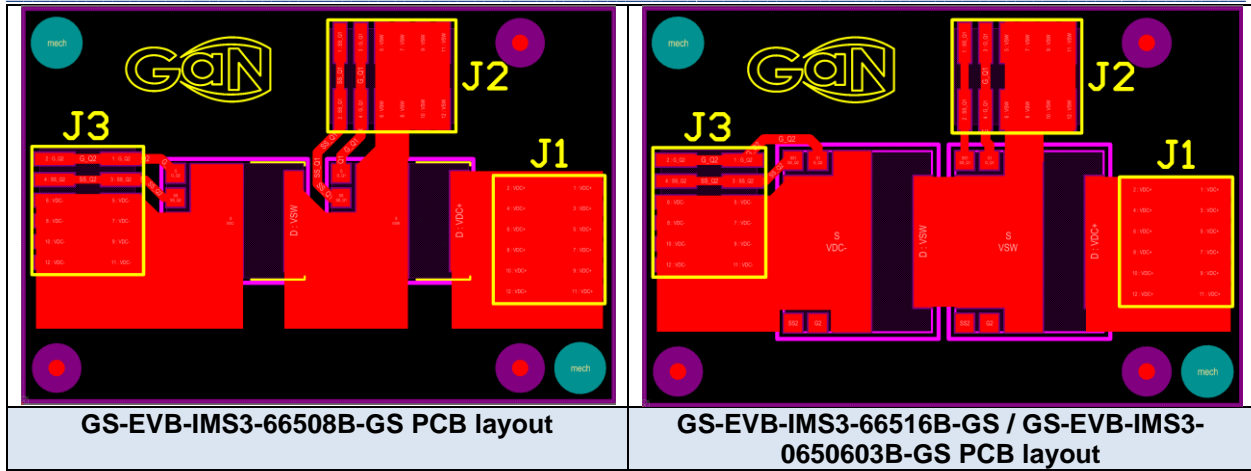

Figure 13 Test waveforms (400Vin, 10kHz, Po=0.8kW)

Ch#1 (blue): Drain-source voltage, 100V/div  
Ch#4 (green): Inductor current, 5A/div

## 6 GS-EVB-IMS3-665xxB-GS Schematics and BoM



**Bill of Materials (BOM)**

<b>GS-EVB-IMS3-0650603B-GS</b>					
Comment	Description	Designator	Quantity	Manufacturer	Manufacturer Part Number
FTS-106-02-X-DV	CONN HEADER SMD 12POS 1.27MM	J1, J2, J3	3	Samtec Inc.	FTS-106-02-F-DV
GS-065-060-3-B	GAN TRANS E-MODE 650V 60A	Q1, Q2	2		
<b>GS-EVB-IMS3-66508B-GS</b>					
Comment	Description	Designator	Quantity	Manufacturer	Manufacturer Part Number
FTS-106-02-X-DV	CONN HEADER SMD 12POS 1.27MM	J1, J2, J3	3	Samtec Inc.	FTS-106-02-F-DV
GS66508B	GAN TRANS E-MODE 650V 30A	Q1, Q2	2		
<b>GS-EVB-IMS3-66516B-GS</b>					
Comment	Description	Designator	Quantity	Manufacturer	Manufacturer Part Number
FTS-106-02-X-DV	CONN HEADER SMD 12POS 1.27MM	J1, J2, J3	3	Samtec Inc.	FTS-106-02-F-DV
GS66516B	GAN TRANS E-MODE 650V 60A	Q1, Q2	2		

---

## Evaluation Board/kit Important Notice

GaN Systems Inc. (GaN Systems) provides the enclosed product(s) under the following **AS IS** conditions:

This evaluation board/kit being sold or provided by GaN Systems is intended for use for **ENGINEERING DEVELOPMENT, DEMONSTRATION, and OR EVALUATION PURPOSES ONLY** and is not considered by GaN Systems to be a finished end-product fit for general consumer use. As such, the goods being sold or provided are not intended to be complete in terms of required design-, marketing-, and/or manufacturing-related protective considerations, including but not limited to product safety and environmental measures typically found in end products that incorporate such semiconductor components or circuit boards. This evaluation board/kit does not fall within the scope of the European Union directives regarding electromagnetic compatibility, restricted substances (RoHS), recycling (WEEE), FCC, CE or UL, and therefore may not meet the technical requirements of these directives, or other related regulations.

If this evaluation board/kit does not meet the specifications indicated in the Technical Manual, the board/kit may be returned within 30 days from the date of delivery for a full refund. **THE FOREGOING WARRANTY IS THE EXCLUSIVE WARRANTY MADE BY THE SELLER TO BUYER AND IS IN LIEU OF ALL OTHER WARRANTIES, EXPRESSED, IMPLIED, OR STATUTORY, INCLUDING ANY WARRANTY OF MERCHANTABILITY OR FITNESS FOR ANY PARTICULAR PURPOSE. EXCEPT TO THE EXTENT OF THIS INDEMNITY, NEITHER PARTY SHALL BE LIABLE TO THE OTHER FOR ANY INDIRECT, SPECIAL, INCIDENTAL, OR CONSEQUENTIAL DAMAGES.**

The user assumes all responsibility and liability for proper and safe handling of the goods. Further, the user indemnifies GaN Systems from all claims arising from the handling or use of the goods. Due to the open construction of the product, it is the user's responsibility to take any and all appropriate precautions with regard to electrostatic discharge.

No License is granted under any patent right or other intellectual property right of GaN Systems whatsoever. **GaN Systems assumes no liability for applications assistance, customer product design, software performance, or infringement of patents or any other intellectual property rights of any kind.**

GaN Systems currently services a variety of customers for products around the world, and therefore this transaction **is not exclusive.**

**Please read the Technical Manual and, specifically, the Warnings and Restrictions notice in the Technical Manual prior to handling the product.** Persons handling the product(s) must have electronics training and observe good engineering practice standards.

This notice contains important safety information about temperatures and voltages. For further safety concerns, please contact a GaN Systems' application engineer.

In Canada:  
GaN Systems Inc.  
770 Palladium Drive, Suite 201  
Ottawa, Ontario, Canada K2V 1C8  
T +1 613-686-1996

In Europe:  
GaN Systems Ltd., German Branch  
Terminalstrasse Mitte 18,  
85356 München, Germany  
T +49 (0) 8165 9822 7260

In the United States:  
GaN Systems Corp. 2723 South State Street,  
Suite 150, Ann Arbor, MI. USA 48104 T +1  
248-609-7643

[www.gansystems.com](http://www.gansystems.com)

Important Notice – Unless expressly approved in writing by an authorized representative of GaN Systems, GaN Systems components are not designed, authorized or warranted for use in lifesaving, life sustaining, military, aircraft, or space applications, nor in products or systems where failure or malfunction may result in personal injury, death, or property or environmental damage. The information given in this document shall not in any event be regarded as a guarantee of performance. GaN Systems hereby disclaims any or all warranties and liabilities of any kind, including but not limited to warranties of non-infringement of intellectual property rights. All other brand and product names are trademarks or registered trademarks of their respective owners. Information provided herein is intended as a guide only and is subject to change without notice. The information contained herein or any use of such information does not grant, explicitly, or implicitly, to any party any patent rights, licenses, or any other intellectual property rights. General Sales and Terms Conditions apply.

© 2009-2022 GaN Systems Inc. All rights reserved.